

## Southern Nevada Health District Sizing Chart for EZflow Disposal Field Systems

EZflow by Infiltrator Systems Inc.

Percolation Rate (Min./Inch)	<b>Septic Tank Size</b>											
	1000 Gallon Tank		1200 Gallon Tank		1500 Gallon Tank		2000 Gallon Tank		2250 Gallon Tank		2500 Gallon Tank	
	Maximum Fixture Units Served: 0 - 20		Maximum Fixture Units Served: 21 - 25		Maximum Fixture Units Served: 26 - 35		Maximum Fixture Units Served: 36 - 45		Maximum Fixture Units Served: 46 - 55		Maximum Fixture Units Served: 56 - 60	
	Minimum Soil Absorption Area of Gravel Required (square feet)	Equivalent Soil Absorption Area of EZflow Required (square feet)	Minimum Soil Absorption Area of Gravel Required (square feet)	Equivalent Soil Absorption Area of EZflow Required (square feet)	Minimum Soil Absorption Area of Gravel Required (square feet)	Equivalent Soil Absorption Area of EZflow Required (square feet)	Minimum Soil Absorption Area of Gravel Required (square feet)	Equivalent Soil Absorption Area of EZflow Required (square feet)	Minimum Soil Absorption Area of Gravel Required (square feet)	Equivalent Soil Absorption Area of EZflow Required (square feet)	Minimum Soil Absorption Area of Gravel Required (square feet)	Equivalent Soil Absorption Area of EZflow Required (square feet)
<b>3</b>	350	245	420	300	520	355	700	490	788	552	875	613
<b>4</b>	400	280	480	335	600	420	800	560	900	630	1000	700
<b>5</b>	450	315	540	380	710	500	900	630	1013	709	1125	788
<b>10</b>	635	445	760	530	950	665	1272	890	1429	1000	1588	1112
<b>15</b>	775	545	935	655	1165	815	1550	1085	1744	1220	1940	1360
<b>30</b>	1100	770	1315	920	1645	1150	2200	1540	2475	1722	2750	1925
<b>45</b>	1345	940	1610	1130	2015	1410	2690	1885	3027	2118	3363	2354
<b>60</b>	1550	1085	1860	1300	2325	1630	3100	2170	3488	2442	3875	2715

- Notes: 1. The maximum length of the distribution line per SNHD regulations is 100 feet.  
 2. A configuration utilizing an odd number of lines or a septic tank capacity greater than 2,000 gallons will require the installation of a distribution box.

# Installation Instructions for EZflow Systems per the Southern Nevada Health District



The Southern Nevada Health District (SNHD) has approved **EZflow** by Infiltrator product as an alternative leach bed or trench material to be used as a replacement for approved gravel and pipe components. The **EZflow** product is to be installed in accordance with manufacturer's instructions and in accordance with the provided details and sizing charts.

## Bed Configurations

The approved **EZflow** products may be used in a bed system designed and installed with equivalent bottom area sizing to a chamber bed system.

## Trench Configurations

The 1202H/1202H-GEO consists of two 12" diameter bundles, one beside the other in a 24"-wide trench. One bundle contains a 4" perforated pipe and the other is aggregate only. The perforated pipe is positioned towards the top of the trench. This model is installed in a standard three-foot deep trench.

The 1203H/1203H-GEO consists of three 12" diameter bundles, one beside the other in a 36"-wide trench. One bundle contains a 4" perforated pipe and the other two are aggregate only. The perforated pipe is positioned towards the top of the trench. This model is installed in a standard three-foot deep trench.

The 1204S/1204S-GEO, consists of two 12" diameter bundles, aggregate only, one beside the other in the bottom of a 24"-wide trench. Two additional bundles are placed on top of the first two. One of these bundles contains a 4" perforated pipe and the other is aggregate only. The perforated pipe is positioned towards the top of the trench. This model is installed in a standard three-foot deep trench.

## MATERIALS AND EQUIPMENT NEEDED

- **EZflow** Bundles
- **EZflow** Internal Pipe Couplers
- **EZflow** Versa Couplers (optional)
- Barrier Material (if not using a GEO product)
- Pipe for Header and Inlet
- Watertight distribution box as needed
- Backhoe
- Laser, Transit or Level

## INSTALLATION INSTRUCTIONS

1. In cases where linear footage required is not in multiples of ten, the installer may (a) reduce the product to the needed length and refasten the netting to the pipe or, (b) use an additional 5 or 10 feet of product to exceed the required trench length.
2. After the SNHD has permitted the **EZflow** system, stake or mark the location of beds or trenches with paint. Be careful to set correct tank, invert pipe, header line or distribution box and bed or trench bottom elevations before installation of EPS pipe bundles.

3. All sites shall meet applicable site, soil, location, separation distance and construction criteria as required by the SNHD.
4. The top of each 1202H-GEO, 1203H-GEO, and 1204S-GEO cylinder contains a filter fabric pre-manufactured in between the netting and aggregate. The fabric is inserted to prevent soil intrusion. The installer shall make sure that the fabric is positioned upward and is in contact with the fabric contained in the adjacent cylinder before backfilling.
5. If not using a GEO product, **EZflow** systems require covering over the top of the system with an untreated building paper or other approved barrier materials.
6. Remove **EZflow** stretch wrap prior to placing bundles in the trench(es). Remove any stretch wrap in the trench before system is covered.
7. Place **EZflow** bundle(s) in the **EZflow** configuration approved by system design permit specified for the particular site. The bundles containing pipe are joined end to end with an internal pipe coupler. Any additional aggregate only bundles that may be required should be butted against the other aggregate-only bundles and do not require any type of connection.
8. If smearing or glazing of bed or trench sidewalls and bottom has occurred in soils containing enough clay or silt, it is recommended that these soil surfaces be raked or scarified.
9. The proper elevation of solid PVC effluent pipe going to each bed or trench should be determined to ensure compliance with the required maximum bed or trench bottom depth per the approved permit. This height may vary dependent on system height and configuration that is used.
10. Leach beds or trenches shall not be installed under driveways, parking areas, or other impervious coverings.
11. The bottom of the bed or trench shall be level or sloped a maximum of 2 inches per 100 feet.
12. Excavate bed or trench to permitted/approved width/depth.
13. Tight lines shall connect leach lines with distribution boxes.
14. Soil backfill shall be a minimum of 12 inches deep and follow **EZflow** guidelines. Soil within 6 inches of the bundles shall be loosely placed and not compacted.
15. Final cover above the bed or trenches shall be mounded to reduce infiltration of surface water and to minimize erosion.

Repeat steps 1 through 15 for each required bed or trench.

## SYSTEM PROTECTION

After the system has been completely covered, never drive across or along the leach bed or trench. To avoid additional soil compaction, prevent any heavy equipment from driving across or along the leach bed or trench area.

Sod or seed the leach field area to control erosion, as may be required by permit or local rules or policy.

## MAINTENANCE

The owner of the system shall at all times properly operate and maintain the onsite sewage disposal system. Only sanitary sewage shall be introduced into the system.

## INSPECTION

An inspection is required by the SNHD prior to covering the sewer line, septic tank and soil absorption system.

Septic tank, header pipe, distribution box, leach bed or trench bottom, grade, depth, and cover shall be in accordance with SNHD regulations and shall be installed per the **EZflow** manufacturer's installation guide.

## BED SYSTEMS

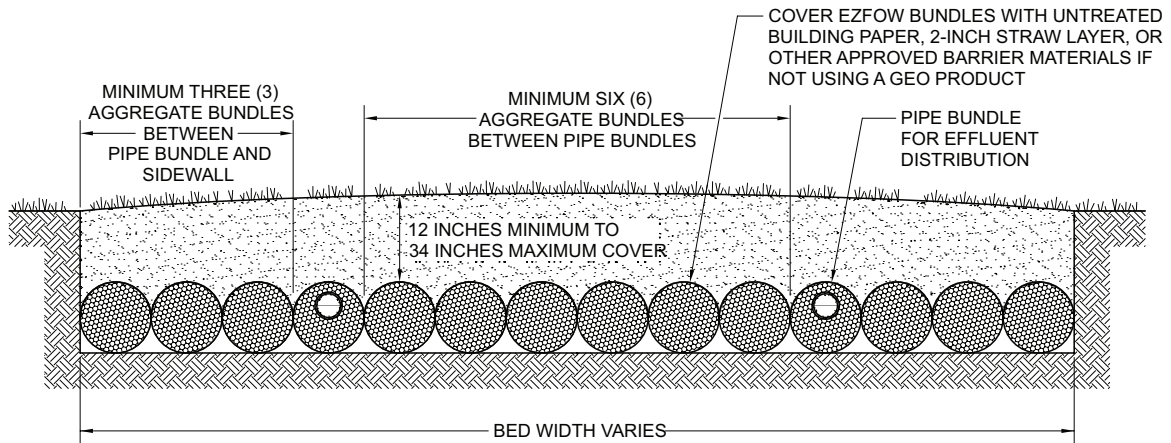

Common Absorption Bed Leach Fields (Absorption areas based on 15 minutes / inch soil percolation rates)				
Septic Tank Capacity (gallons)	Required Absorption Bottom Area (square feet)	EZflow Bed Configuration*		
		Footprint		Absorption Area Provided (square feet)
		Bed Width (feet)	Bed Length (feet)	
1,000	545	14	40	560
1,250	655	17	40	680
1,500	815	21	40	840
2,000	1,085	22	50	1,100
2,250	1,220	25	50	1,250
2,500	1,360	23	60	1,380

\* Other bed length / width configurations may be allowed and approved by the SNHD. The maximum length of a distribution line per SNHD regulations is 100 feet.

Recommended Number of Effluent Distribution Lines	
Bed Width (feet)	Number of Lines
14 - 20	2
21 - 27	3
28 - 34	4
35 - 41	5
42 - 47	6

Notes: A bed configuration utilizing an odd number of distribution lines or a septic tank capacity greater than 2,000 gallons will require the installation of a distribution box.

## TRENCH SYSTEMS

Unit	Dimensions W x H (in.)	Trench Width	Leaching Area (SF/LF)
1202H	24 x 12	24"	3.0
1203H	36 x 12	36"	4.0
1204S	24 x 24	24"	5.0

Note: The maximum length of the distribution line per SNHD regulations is 100 feet.

### EZ<sub>flow</sub> 1202H or 1202H-GEO

48" - 92" SPACING BETWEEN ADJACENT TRENCH SIDEWALLS (TWICE THE EXCAVATION DEPTH)

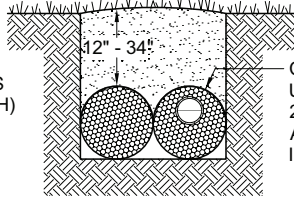

COVER EZFLOW BUNDLES WITH UNTREATED BUILDING PAPER, 2-INCH STRAW LAYER, OR OTHER APPROVED BARRIER MATERIALS IF NOT USING A GEO PRODUCT

**SIZING EXAMPLE:** 900 sq. ft. required  
 $900 \text{ sf} \div 3.0 \text{ sf/lf} = 300 \text{ lf}$  required

Properties & Specifications	
Overall System Height	12"
Trench Width	24"
Trench Depth	24" - 46"
Trench Sizing	3.0 sf/lf

### EZ<sub>flow</sub> 1203H or 1203H-GEO

48" - 92" SPACING BETWEEN ADJACENT TRENCH SIDEWALLS (TWICE THE EXCAVATION DEPTH)

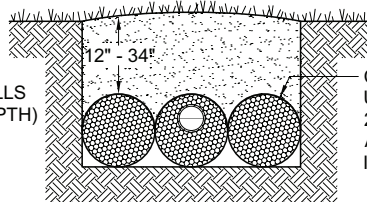

COVER EZFLOW BUNDLES WITH UNTREATED BUILDING PAPER, 2-INCH STRAW LAYER, OR OTHER APPROVED BARRIER MATERIALS IF NOT USING A GEO PRODUCT

**SIZING EXAMPLE:** 900 sq. ft. required  
 $900 \text{ sf} \div 4.0 \text{ sf/lf} = 225 \text{ lf}$  required

Properties & Specifications	
Overall System Height	12"
Trench Width	36"
Trench Depth	24" - 46"
Trench Sizing	4.0 sf/lf

### EZ<sub>flow</sub> 1204S or 1204S-GEO

72" - 116" SPACING BETWEEN ADJACENT TRENCH SIDEWALLS (TWICE THE EXCAVATION DEPTH)

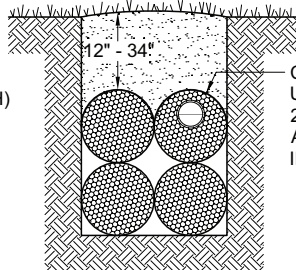

COVER EZFLOW BUNDLES WITH UNTREATED BUILDING PAPER, 2-INCH STRAW LAYER, OR OTHER APPROVED BARRIER MATERIALS IF NOT USING A GEO PRODUCT

**SIZING EXAMPLE:** 900 sq. ft. required  
 $900 \text{ sf} \div 5.0 \text{ sf/lf} = 180 \text{ lf}$  required

Properties & Specifications	
Overall System Height	24"
Trench Width	24"
Trench Depth	36" - 58"
Trench Sizing	5.0 sf/lf

## TRENCH SIZING

Percolation Rate (Min. / Inch)		SEPTIC TANK SIZE											
		1000 Gallon Tank (Maximum Fixture Units Served: 0-20)				1200 Gallon Tank (Maximum Fixture Units Served: 21-25)				1500 Gallon Tank (Maximum Fixture Units Served: 26-35)			
		Square Feet Gravel Required	1202H & 1202H-GEO 2'W x 1'H x 10'L	1204S & 1204S-GEO 2'W x 2'H x 10'L	1203H & 1203H-GEO 3'W x 1'H x 10'L	Square Feet Gravel Required	1202H & 1202H-GEO 2'W x 1'H x 10'L	1204S & 1204S-GEO 2'W x 2'H x 10'L	1203H & 1203H-GEO 3'W x 1'H x 10'L	Square Feet Gravel Required	1202H & 1202H-GEO 2'W x 1'H x 10'L	1204S & 1204S-GEO 2'W x 2'H x 10'L	1203H & 1203H-GEO 3'W x 1'H x 10'L
Sizing 3.0 SF/LF	Sizing 5.0 SF/LF		Sizing 4.0 SF/LF	Sizing 3.0 SF/LF	Sizing 5.0 SF/LF		Sizing 4.0 SF/LF	Sizing 3.0 SF/LF	Sizing 5.0 SF/LF		Sizing 4.0 SF/LF	Sizing 3.0 SF/LF	Sizing 5.0 SF/LF
3	SF	350	245	245	245	420	294	294	294	520	364	364	364
	Units	9	5	7			10	6	8		13	8	10
4	SF	400	280	280	280	480	336	336	336	600	420	420	420
	Units	10	6	7			12	7	9		14	9	11
5	SF	450	315	315	315	540	378	378	378	710	497	497	497
	Units	11	7	8			13	8	10		17	10	13
10	SF	635	445	445	445	760	532	532	532	950	665	665	665
	Units	15	9	12			18	11	14		23	14	17
15	SF	775	543	543	778	935	655	655	655	1165	816	816	816
	Units	19	11	14			22	14	17		28	17	21
30	SF	1100	770	770	770	1315	921	921	921	1645	1152	1152	1152
	Units	26	16	20			31	19	24		39	24	29
45	SF	1350	942	942	942	1610	1127	1127	1127	2015	1411	1411	1411
	Units	32	19	24			38	23	29		48	29	36
60	SF	1550	1085	1085	1085	1860	1302	1302	1302	2325	1628	1628	1628
	Units	37	22	28			44	27	33		55	33	41

Percolation Rate (Min. / Inch)		SEPTIC TANK SIZE											
		2000 Gallon Tank (Maximum Fixture Units Served: 36-45)				2250 Gallon Tank (Maximum Fixture Units Served: 46-55)				2500 Gallon Tank (Maximum Fixture Units Served: 56-60)			
		Square Feet Gravel Required	1202H & 1202H-GEO 2'W x 1'H x 10'L	1204S & 1204S-GEO 2'W x 2'H x 10'L	1203H & 1203H-GEO 3'W x 1'H x 10'L	Square Feet Gravel Required	1202H & 1202H-GEO 2'W x 1'H x 10'L	1204S & 1204S-GEO 2'W x 2'H x 10'L	1203H & 1203H-GEO 3'W x 1'H x 10'L	Square Feet Gravel Required	1202H & 1202H-GEO 2'W x 1'H x 10'L	1204S & 1204S-GEO 2'W x 2'H x 10'L	1203H & 1203H-GEO 3'W x 1'H x 10'L
Sizing 3.0 SF/LF	Sizing 5.0 SF/LF		Sizing 4.0 SF/LF	Sizing 3.0 SF/LF	Sizing 5.0 SF/LF		Sizing 4.0 SF/LF	Sizing 3.0 SF/LF	Sizing 5.0 SF/LF		Sizing 4.0 SF/LF	Sizing 3.0 SF/LF	Sizing 5.0 SF/LF
3	SF	700	490	490	490	788	522	522	522	875	613	613	613
	Units	17	10	13			19	12	14		21	13	16
4	SF	800	560	560	560	900	630	630	630	1000	700	700	700
	Units	19	12	14			21	13	16		24	14	18
5	SF	900	630	630	630	1013	709	709	709	1125	788	788	788
	Units	21	13	16			24	15	18		27	16	20
10	SF	1272	890	890	890	1429	1000	1000	1000	1588	1112	1112	1112
	Units	30	18	23			34	21	26		38	23	28
15	SF	1550	1085	1085	1085	1744	1221	1221	1221	1940	1358	1358	1358
	Units	37	22	28			41	25	31		46	28	34
30	SF	2200	1540	1540	1540	2475	1733	1733	1733	2750	1925	1925	1925
	Units	52	31	39			58	35	44		65	39	49
45	SF	2690	1883	1883	1883	3027	2119	2119	2119	3363	2354	2354	2354
	Units	63	38	48			71	43	53		79	48	59
60	SF	3100	2170	2170	2170	3488	2442	2442	2442	3875	2713	2713	2713
	Units	73	44	55			82	49	62		91	55	68

**Notes:**

1. The maximum length of the distribution line per SNHD regulations is 100 feet.
2. A configuration utilizing an odd number of lines or a septic tank capacity greater than 2,000 gallons will require the installation of a distribution box.



**INFILTRATOR®**  
systems inc.

6 Business Park Road • Old Saybrook, CT 06475 • 800.689.7759

# Trench Sizing of EZflow Systems In Southern Nevada Health District



EZflow leaching area credits per linear foot of trench are calculated by measuring the trench bottom area and sidewall areas (both sides) below the distribution pipe invert. The equation is as follows:

$$\text{Leaching Area} = \text{Bottom Area} + (2 \times \text{Sidewall Area Below the Pipe Invert})$$

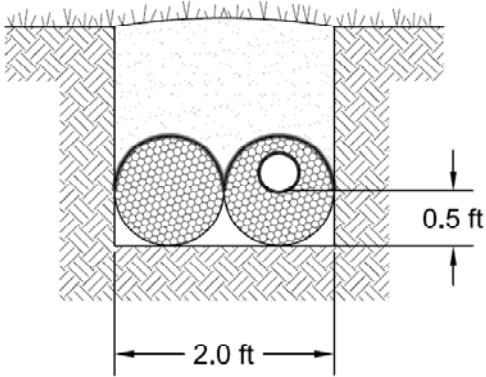

## 1202H or 1202H-GEO

$$\text{Leaching Area} = \text{Bottom Area} + (2 \times \text{Sidewall Area})$$

$$\text{Leaching Area} = 2.0 \text{ sf} + (2 \times 0.5 \text{ sf}) = 3.0 \text{ sf}$$

3.0 sf / linear trench foot

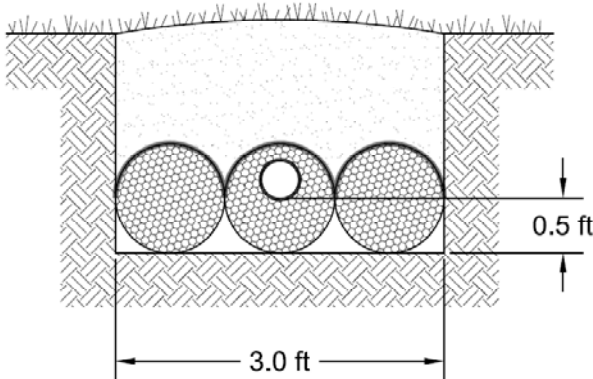

## 1203H or 1203H-GEO

$$\text{Leaching Area} = \text{Bottom Area} + (2 \times \text{Sidewall Area})$$

$$\text{Leaching Area} = 3.0 \text{ sf} + (2 \times 0.5 \text{ sf}) = 4.0 \text{ sf}$$

4.0 sf / linear trench foot

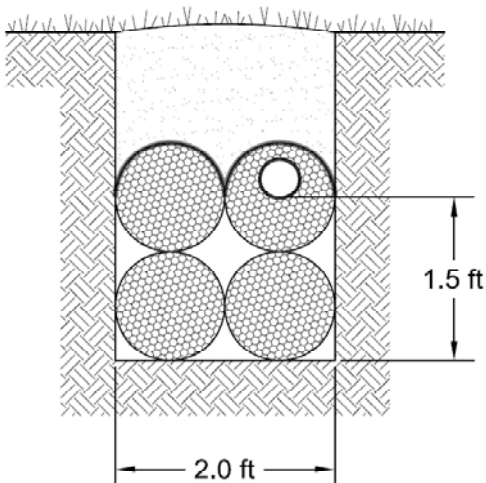

## 1204S or 1204S-GEO

$$\text{Leaching Area} = \text{Bottom Area} + (2 \times \text{Sidewall Area})$$

$$\text{Leaching Area} = 2.0 \text{ sf} + (2 \times 1.5 \text{ sf}) = 5.0 \text{ sf}$$

5.0 sf / linear trench foot